

THE UNITED REPUBLIC OF TANZANIA  
MINISTRY OF HEALTH.

RUKWA REGIONAL

*Tel. No 025 280 2078/2251*

*Fax No. 025 280 0224*

*Email: moi@sumbawangarrh.go.tz*



Sumbawanga Regional Referral  
Hospital ,  
P.O.Box 413,  
SUMBAWANGA.

05<sup>th</sup> April, 2022

## Local Purchase Order for Procurement of Goods

**To: MACWAYS GENERAL SUPPLY  
P.O BOX 149.  
SUMBAWANGA.**

Your quotation dated 04/04/2022 is accepted and you are required to supply the goods as detailed on the attached Schedule of Requirements and Prices against the terms and conditions contained in this Local Purchase Order (LPO). This order is placed subject to the attached General Condition of Contract for LPO, except where modified by the terms stated below.

**TERMS AND CONDITIONS OF THIS LOCAL PURCHASE ORDER:**

- 1. Contract Sum: The Contract Sum Five Million One Hundred Sixty Thousand and Five Hundred Shillings Only. (5,160,500)**
- 2. Delivery Period: The goods are to be delivered within 7 days from the date of this Local Purchase Order.**
- 3. Delivery point: The goods are to be delivered to MEDICAL OFFICER INCHARGE SUMBAWANGA REGIONAL REFERRAL HOSPITAL P.O. BOX 413, SUMBAWANGA.**
- 4. Payment to Supplier:**

The following documents must be supplied for payments to be made:

- An original of an Invoice;
- A delivery note evidencing dispatch of the goods.

SCHEDULE OF REQUIREMENTS AND PRICES

Item No.	Description	Unit of Measure	Quantity	Unit Price TZS.	Total Price TZS.	Warranty Period (Where applicable)
1.	Cement 52.6 N	Bag	61	18,500	1,128,5000	
2.	Sand	Trip	03	70,000	210,000	
3.	Coarse aggregates	Trip	02	380,000	760,000	
4.	Solid concrete blocks, average 5mpa	No.	950	2,300	2,185,000	
5.	Reinforcement 12mm diameter bars high tensile	Pcs	22	28,500	627,000	
6.	Binding Wire 1kgs	Pcs	10	4,000	40,000	
7.	Supporting props	pcs	10	5,000	50,000	
8.	Untreated timber 1x8'x3.6M long	Pcs	12	9,000	108,000	
9.	Untreated timber 2'x4'x3.6M long	Pcs	05	5,000	25,000	
10.	Assorted wire nails 3&4'	Kgs	06	4,500	27,000	
Total Amount in TZS. (including VAT)					5,160,500	

For Purchaser:

Signature: *SPR*

Name: *Dr. GILBERT G. MUSA*

Designation: *Ag. MoJ*

Date: *06/04/2022*

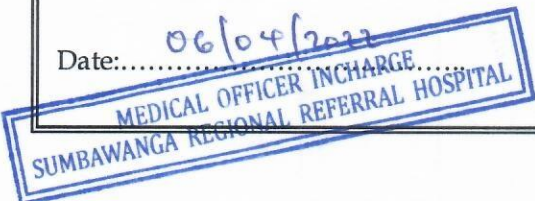

For Supplier:

Signature: *Edina Jusia*

Name: *EDINA JUSIA*

Designation: *Secretary*

Date: *06/04/2022*

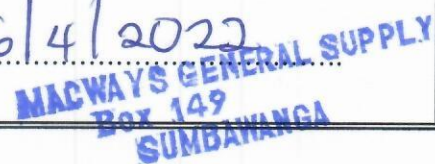

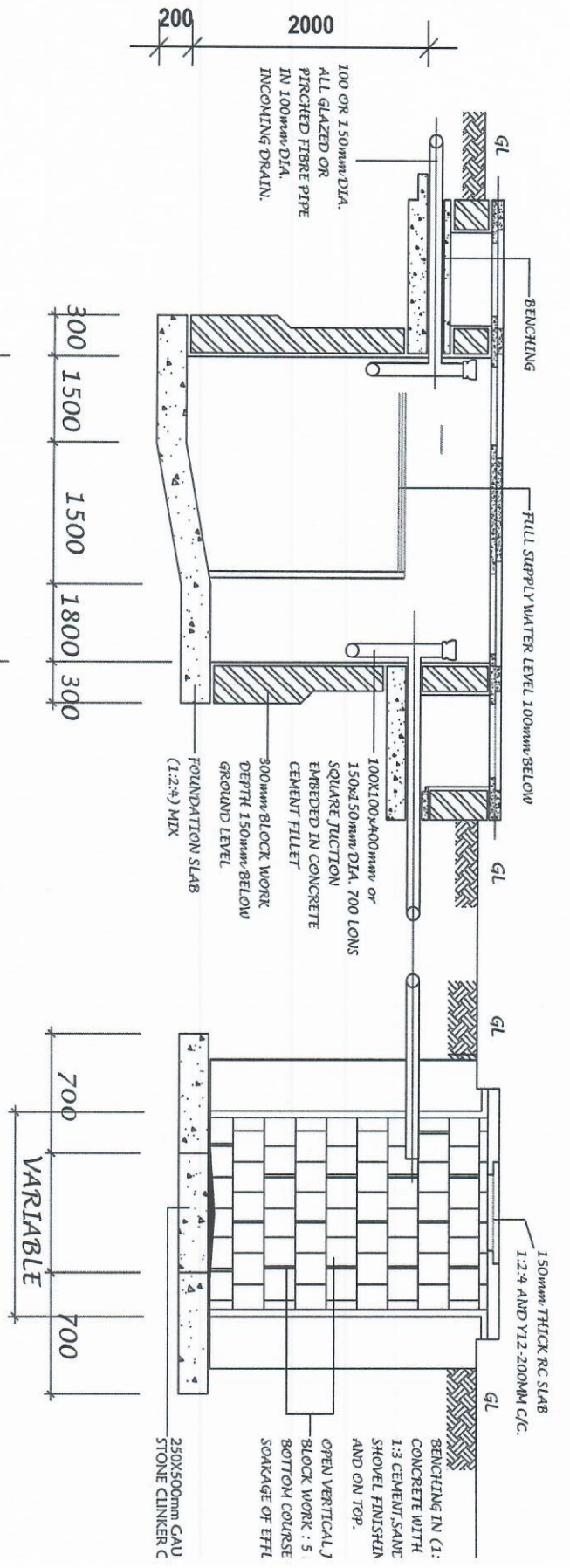

LONGITUDINAL SECTION A - B

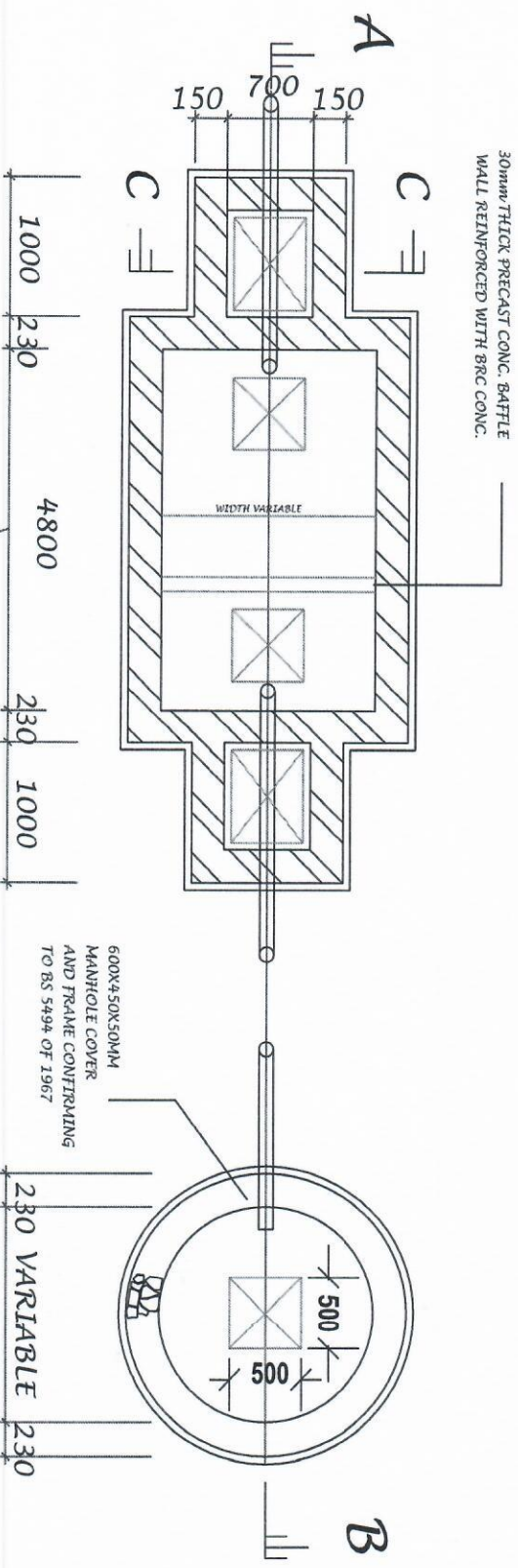

30mm THICK PRECAST CONC. BATTLE WALL REINFORCED WITH BRC CONC.

600X450X50MM MANHOLE COVER AND FRAME CONFORMING TO BS 5494 OF 1967

MIN	RE
DISTANC	
MINIM	
B	
P	
A	
C	
L	
TYPES	
1	
2	
3	